

Type 19-430-10

UHF SatCOM Antenna
225 MHz - 400 MHz

COBHAM

19-430-10-DS Issue 1

The most important thing we build is trust



The **19-430-10 UHF SatCOM Antenna** is a combined low-high angle, low weight, high efficiency airborne UHF satellite communications antenna operating in the 225 MHz - 400 MHz frequency band.

The antenna provides essentially hemispherical pattern coverage by means of two independent collocated elements built into a single, aerodynamic shell.

A variant of the **19-430-10**, the **19-430-10N**, offers alternative types of connector.

The **19-430-10** comprises two independent elements:

- A circularly polarised turnstile antenna comprising a pair of quadrature connected broadband horizontal crossed dipoles, fed via a pair of broadband baluns. The antenna is polarised Right Hand Circular (RHCP) according to IEEE definition. RHCP is interpreted as clockwise circular polarisation approaching an observer.
- A vertically polarised, reactively matched, broadband sleeved monopole.

Low angle coverage is provided by the vertical element and high angle coverage is provided by the circularly polarised element. In this way, essentially full hemispherical coverage is achieved over the specified operating band.

The **19-430-10** utilises a one-piece, vertical, shell moulded under heat and pressure for high strength and resistance to moisture ingress.

The horizontal element is contained within a circular, fibreglass, moulding which is securely and permanently fitted to the vertical shell.

An aluminium alloy base plate provides for fixing the antenna to the airframe. Careful design of internal ribs and base-to-shell load transfer ensures very high side loading acceptance.

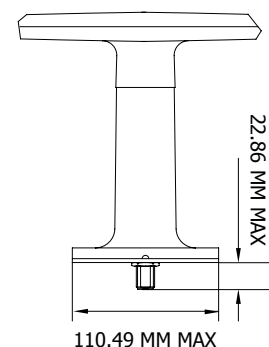
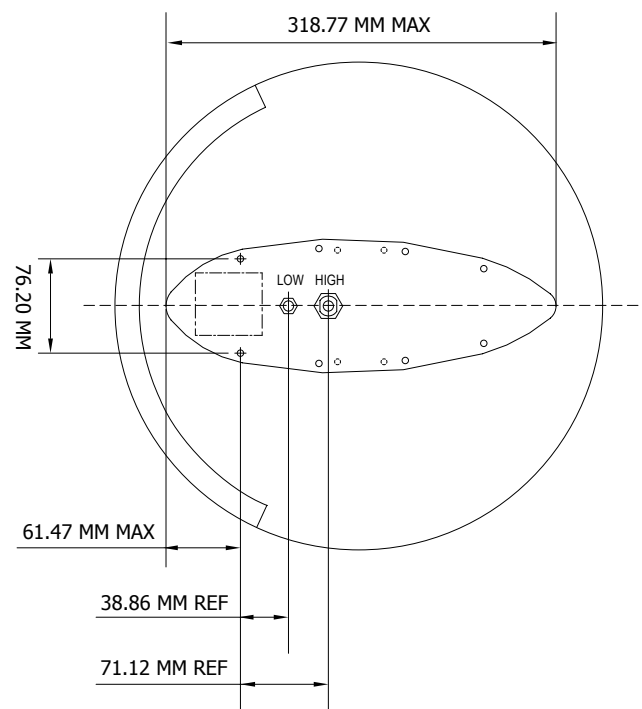
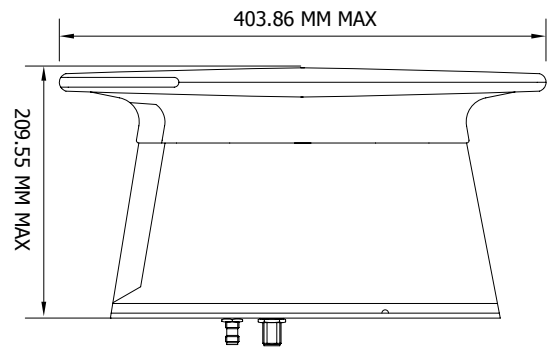

Type 19-430-10

UHF SatCOM Antenna



Electrical Specification

Frequency	225 MHz - 400 MHz		
Gain	Low Angle:	Average within 2 dB of a quarter-wave monopole (+4 dBi typical)	
	High Angle:	+4.5 dBiC minimum (average full band) at zenith (+6 dBiC typical at zenith)	
Polarisation	Low Angle:	Essentially vertical when mounted vertically	
	High Angle:	Predominantly RHCP at zenith	
Power Rating	200 W max		
Impedance	50 Ohm nominal		
VSWR	Low Angle:	2.0:1 max	
	High Angle:	2.0:1 max	
Isolation	≥ 20 dB (mid-band)		
Connectors	Type	Low Angle	High Angle
	19-430-10 19-430-10N	TNC Type Female N Type Female	N Type Female N Type Female

Mechanical Specification

Height	209.55 mm
Width	403.86 mm
Weight	3.4 kg
Mounting	8 holes fixed location

Environmental Specification

High Temperature	MIL-STD-810D, Method 501.2, Procedures I and II
	Operational: +71°C Storage: +85°C
Low Temperature	MIL-STD-810D, Method 502.2, Procedures I and II
	Operational: -54°C Storage: -57°C
Altitude	MIL-STD-810D, Method 500.2, Procedure II 50,000 feet
Acceleration	MIL-STD-810E, Method 513.4, Procedure I 13.5 g all axes
Shock	MIL-STD-810E, Method 516.4, Procedures I and V
	Functional: 20 g, 11 ms, sawtooth Crash Hazard: 40 g, 11 ms, sawtooth
Vibration	MIL-STD-810C, Method 516.2, Procedure I
	Functional: 15 g, 11 ms, half sine
Vibration	MIL-STD-810E, Method 514.4, Procedure I, Category 4 0.01 g ² /Hz, 15 Hz - 2000 Hz, L1 = 0.6 g ² /Hz at 68 Hz
	MIL-STD-810E, Method 514.4, Procedure I, Category 4 0.1 g ² /Hz, 15 Hz - 2000 Hz, L1 = 0.6 g ² /Hz at 95 Hz
	MIL-STD-810E, Method 514.4, Procedure I, Category 5
	MIL-STD-810E, Method 514.4, Procedure I, Category 10
Temperature Shock	MIL-STD-810E, Method 503.3, Procedure I
Rain	MIL-STD-810C, Method 506.1, Procedure I Normal operation when exposed to driving rain
Humidity	MIL-STD-810C, Method 507.1, Procedure I 95% relative humidity at 60°C
Salt Fog	MIL-STD-810D, Method 509.2, Procedure I 48 hours exposure to 5% salt solution
Magnetic Effect	Less than 1° deflection at 300 mm

For further information please contact:

Cobham Antenna Systems
The Cobham Centre
Fourth Avenue, Marlow
Buckinghamshire
SL7 1TF

Tel: +44 (0)1628 472072
Fax: +44 (0)1628 482255
Email: antennasystems.marlow.marketing@cobham.com